

# Simple stomp rocket - \$6

Assemble the parts below. Joints can be glued or simply press fit. The grey conduit coupler is more flexible than white PVC and will allow the soda bottle's neck to be jammed/screwed in securely.

Rockets are made by loosely wrapping a half sheet (4 ¼ x 11) of card stock or construction paper around the removable launch tube and taping the seam lengthwise. Fins are added or cut into the bottom of the tube. Pinch the top shut and tape securely.

Slide rocket over tube and stomp away!

## Materials

1 - 8' of ¾" PVC conduit (uses 5 ½')	\$2.00
1 - ¾" PVC cross fitting	1.70
2 - ¾" PVC end cap	.72
1 - ¾" PVC conduit (grey) coupling	.50
1 - ¾" PVC elbow (slip/female thread)	.53
1 - ¾" PVC adapter (slip/male thread)	.53

- 2 liter soda bottle
- Card stock or construction paper
- Tape
- PVC glue (if desired)

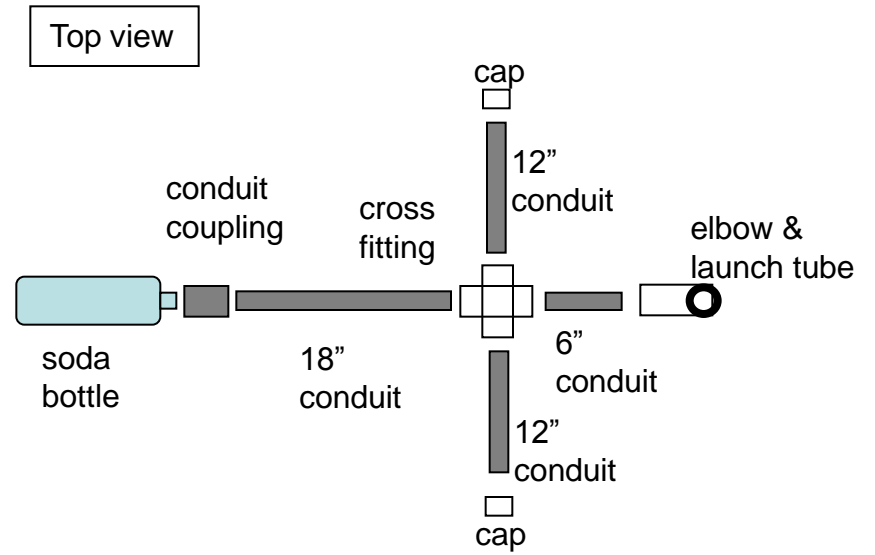
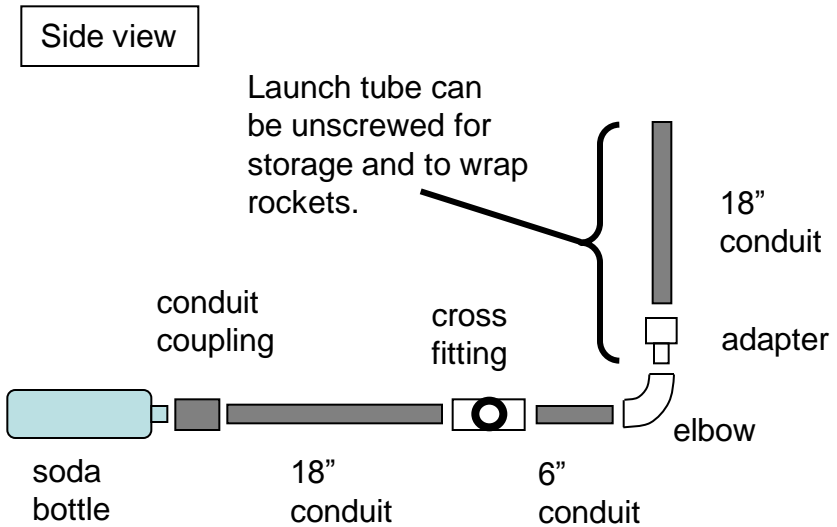

# Simple straw rocket launcher less than \$10

Assemble the parts below. Most joints can be press fit. The plunger cap must be glued. Use Schedule 40 tubing for the 1 ¼” parts to ensure a good fit with the plunger. Drill a 7/32” hole in the ½” plug and fit the 7/32” tubing (if the fit is loose use epoxy to secure). Cut a rubber band and fit it over the cylinder, securing the ends with the hose clamp.

The ½” elbow must be press fit (no glue) to allow the launch tube to rotate.

Put markings (every ½” or so) on plunger to ensure repeatable launches. Mark angles on front of base to experiment with launch angles and trajectory.

Rockets are made by pinching and taping shut the top of a ¼” straw. For fins, use tape cut to shape.

Lift plunger, slide rocket over tube, and release plunger to launch. Power can be increased by increasing the initial tension on the rubber band. Efficiency is improved by wrapping teflon (plumbing) tape 5-7 times around the bottom of the plunger tube. Wrap for close, but not snug fit. Looser fit is needed if you wish to launch without the rubber band. Tighter fit gives more power; too tight will bind. The fit may loosen with use requiring you to occasionally add one additional wrap of teflon.

Variations – the 1” plunger and 1 ¼” cylinder can be 12”-18” long. Longer tube allows short range indoor launches using the plunger’s weight for power (no rubber band). For high powered outdoor use install two rubber bands.

## Materials/Parts

1 - ½” PVC tubing/conduit (6”)	\$ .50
1 - 1” PVC tubing (18”)	.80
1 - 1 ¼” Sch 40 PVC tubing (18”)	1.02
1 - 1’ of 7/32” brass tubing	1.73
1 - 1 ¼” PVC elbow	.83
1 - 1 ¼” – ½” PVC adapter plug(s)	1.50
1 - 1” PVC cap	.53
1 - ½” PVC elbow	.28
1 - ½” PVC plug	.43
1 - 2” wide x 3” long U-bolt	1.00
1 - 2” hose clamp	.92

¼” straight straws  
Tape  
Scrap wood for base  
Rubber band  
PVC glue / Teflon tape

7/32” tubing is selected to fit inside common ¼” straws. You can substitute tubing to fit the straws you can find. You can also use a narrow straw for the launch tube and wider straws that will fit over it for rockets. Close fit is fine, perfection not required.

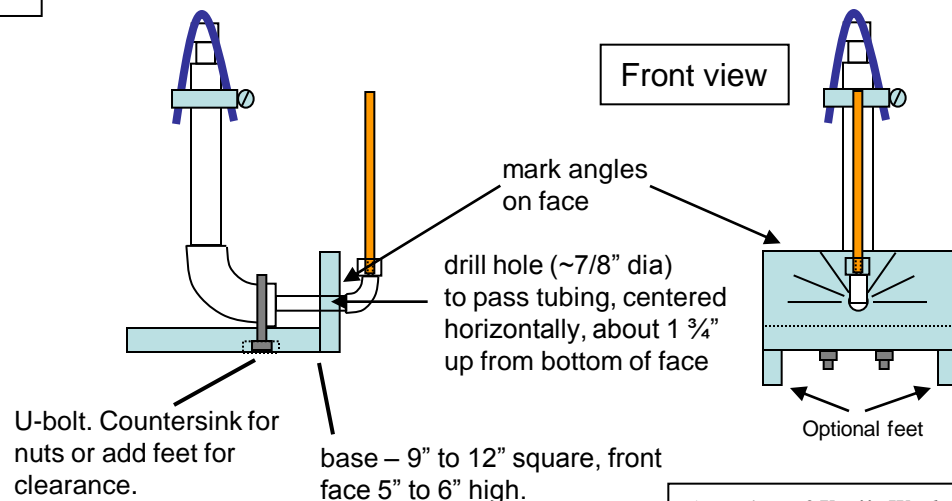
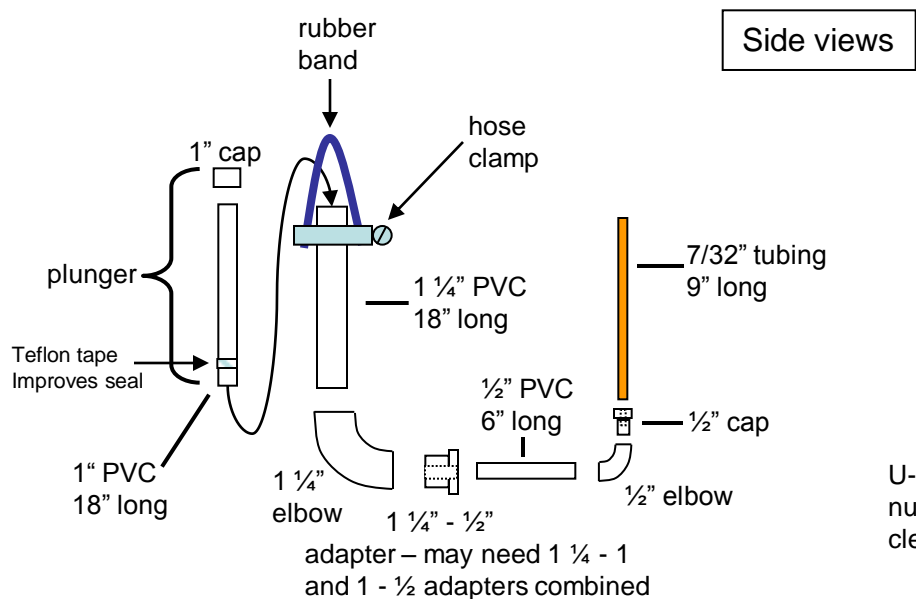

# Straw Rocket

Nose: pinch shut and tape closed. Add additional wraps of tape for weight if needed. Alternately, straw can be plugged with clay, a cut down pencil eraser, etc.

Fins: wrap tape around bottom of straw as shown (1). Pinch the two "fins" flat (2). Trim the tape to desired shape (3).

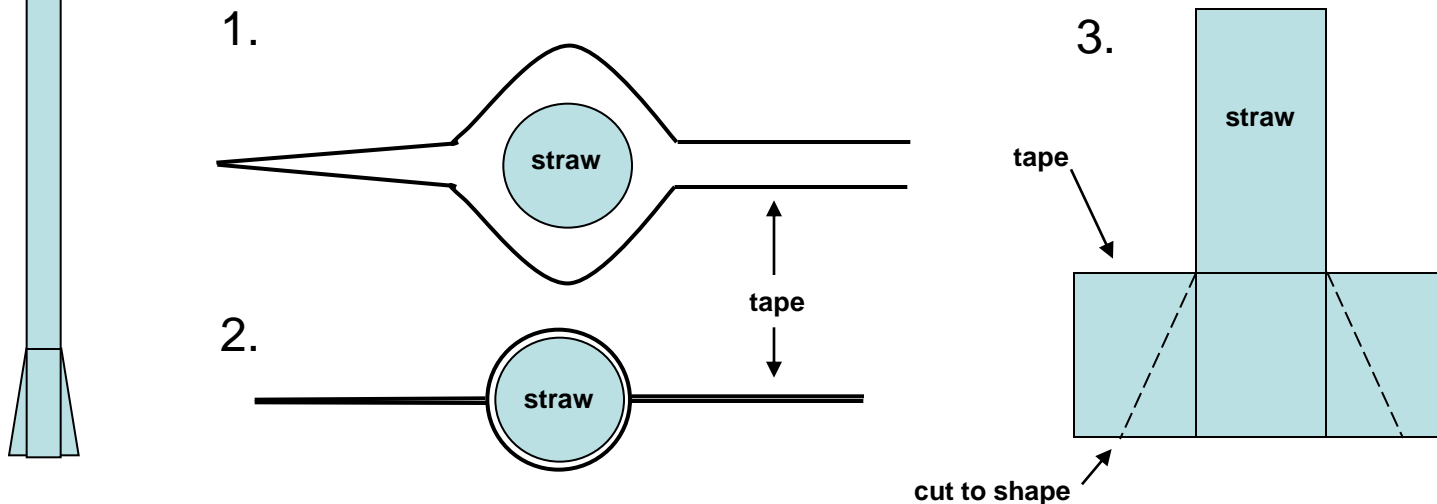

## Tuning the launcher:

Fit the rubber band(s) over the 1 ¼" cylinder with the plunger removed, then secure the bands with the hose clamp. This will pre-tension the system when the bands are stretched over the plunger and provide more consistent force at low settings. For outdoor use, fitting additional rubber bands provides more force; however, the light rockets clear the launch tube so quickly that little change will be seen. Save this trick for launching heavier rockets.

Rockets are powered by air pressure and cease to accelerate as soon as they clear the launch tube. For this reason, there is an upper force limit for any specific rocket weight/length combination – the point where the rocket clears the launch tube just as the plunger bottoms out. Launching beyond this limit provides almost no additional performance as the rocket will have left the launch tube before additional air pressure is used. Adding weight to the rocket or lengthening the rocket body (longer straw or taping two straws end-to-end) allows this power to be used – but these heavier rockets also require more power to launch.

Wrap teflon (plumbing) tape 5-7 times around the bottom of the plunger tube for the initial fitting. A good fit allows the plunger to drop freely under its own weight and should launch straws at least 10-15 feet without the rubber band. Too loose a fit will lack power; add 1-2 additional wraps of tape – check again. Too tight, the plunger will bind and will not drop under its own weight. Remove a wrap of tape – check again. You may be able to use thumb pressure on the tape wraps to compress/smooth the seal instead. The fit will loosen with use requiring you to occasionally add an additional wrap of teflon.

## Straw Rocket: nose

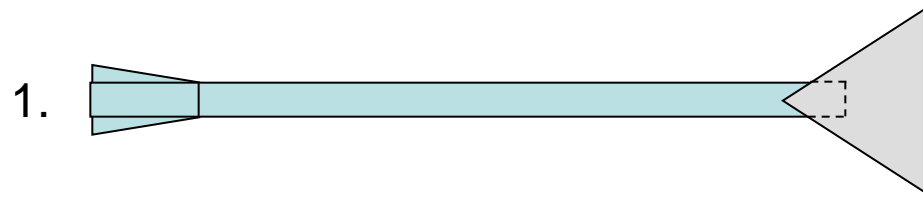

Place triangular piece of tape on nose.

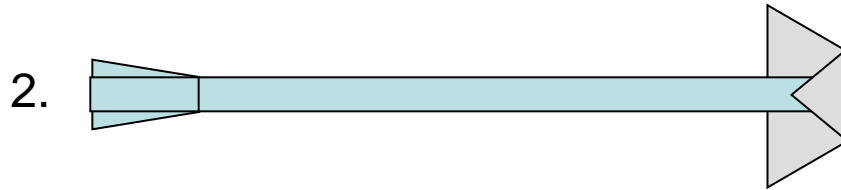

Pinch straw shut and fold tape over the nose.

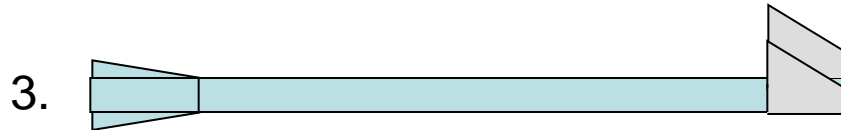

Wrap remaining tape around straw to seal.



## Straw Rocket: fins

Fins: wrap tape around bottom of straw as shown (1).

Pinch the two "fins" flat (2).

Trim the tape to desired shape (3).

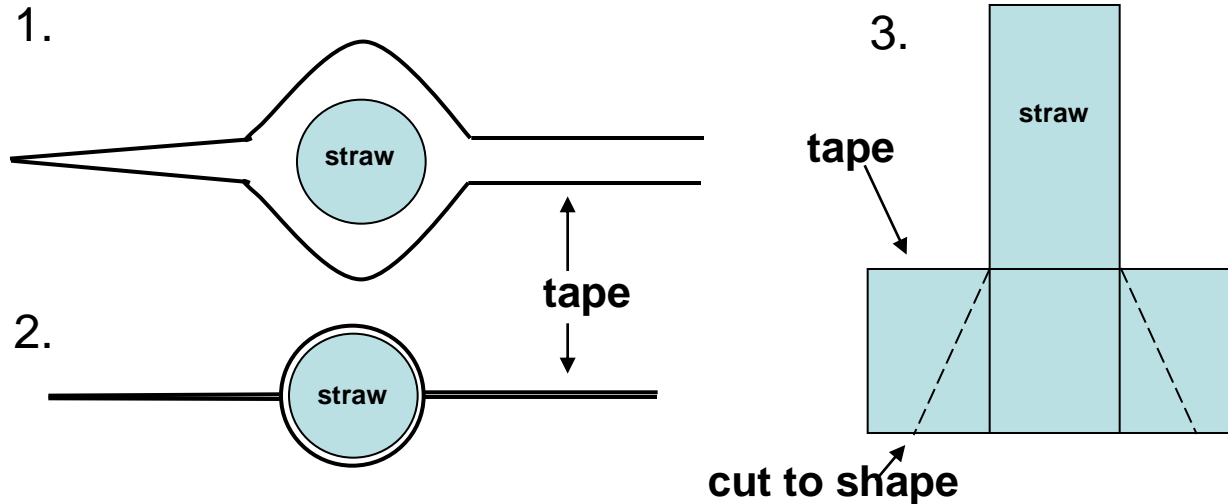

# Classroom topics

Straw rockets can be used to explore several areas qualitatively. Variations in force from the rubber band powering the system preclude much precision. Repeatable relative trials can be done.

You can start by analyzing the launcher and rockets. Volume of the plunger for each inch of movement: cylinder 1" diameter (area  $\frac{1}{2}$  inch squared times pi) by 1" tall = .78 cubic inches. Volume of rocket: cylinder  $\frac{7}{32}$ " diameter by length of straw = .04 cubic inches per inch of straw.

You can estimate the strength of the rubber band (force available) by weighing the launcher, then picking it up by the top of the plunger and measuring how far the plunger extends. Assuming a linear relationship, the force per inch is the weight divided by the extension.

Rockets can be weighed then balanced across a rule to find the center of gravity. Center of pressure can be easily found if you make the fins as wide as the straw, then break the profile up into equal blocks and find where you have half ahead and half behind.

Trajectory – launch several rockets using the same force at varying angles. Graph the distance and height reached at each angle. Discuss which angles give maximum range and/or altitude and why.

Vectors – same trial as above. Using constant force, observe vertical and horizontal components of the motion. Show horizontal velocity relatively constant (allowing for air resistance) while vertical velocity varies with acceleration of gravity.

Pressure – discuss hydraulic multiplication. Area under plunger is 1" in diameter (area .78 sq in). One pound of force yields 1.28 psi (force/area). Launch tube opening is  $\frac{3}{16}$ " inside diameter (area .03 sq in). For each pound of force on the plunger (1.28 psi) the rocket sees only .04 pounds force (pressure times area). That's why it doesn't pop like a balloon. That is also the force that launches it. Of course, air is compressible so actual situation is far more complex ...

Assuming away compressibility, moving a 1" cylinder of air (.78 cu in) with the plunger generates a column of air 26" long (.78 cu in/.03 sq in area) coming out the launch tube – and so the rocket is (again) launched. You can think of this as a velocity multiplication, moving the plunger 1" per second moves the rocket 26" in that same time.

Aerodynamics – you can build rockets with the fins at the front, middle, and back to see the effect on stability of having the center of pressure forward, even with, or aft of the center of gravity (leads to more discussion of force vectors thrust, drag, gravity, etc.). You can also tape various configurations of wings to the straw and move them fore and aft to see the effects.

Etc. The apparatus can be an adjunct activity to existing math and science lessons on: areas, volumes, vectors, gravity, accelerated motion, air resistance, center of gravity & pressure (rockets), stability, etc... You can launch any light object that you can stick a straw in/to – launcher gives you repeatable launch conditions for paper airplanes, etc.

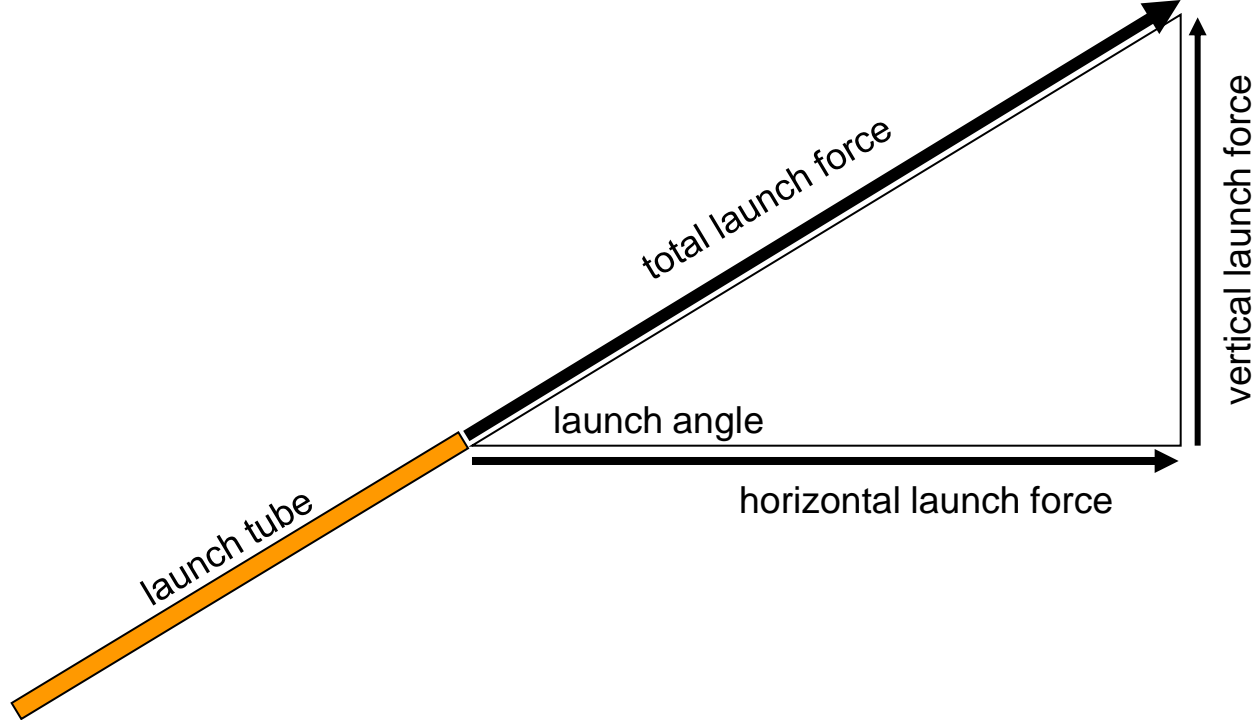

### Unbalanced forces on the rocket at launch

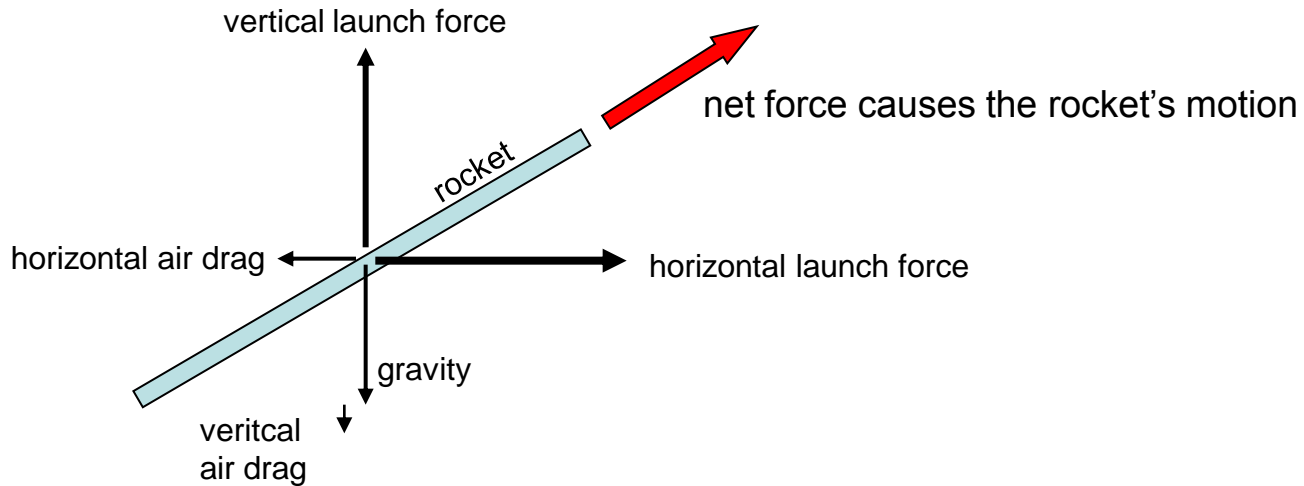

# Measuring height

## Similar Triangles/Right Triangles:

To stimulate students interest in mathematics, you can precisely measure the height of each rocket's flight using a simple 3-4-5 right triangle and some string.

1. Draw the pattern below onto some card stock and assemble as shown. Attach the string and weight.
2. To use, one student holds the triangle steady with the string just touching as shown to ensure the sight is level – this forms a right triangle (vertical direction is perpendicular to horizontal). Another student sights along the top (hypotenuse).
3. To determine the height of a rocket's flight the students will need to watch several trials (one team is the measuring team while another is the launching team). Have the students move toward or away from the rocket until they can just see the rocket make it over the top of the sight.
4. Measure the distance from the student sighting the rocket to the launcher or reference line. Measure the height of the student's eye when sighting.
5. Show the students that the sight and the geometry of the rocket's flight plus their eye's location form similar triangles.
6. Explain to the students the "magic" of the 3-4-5 triangle in a way appropriate for their grade level (i.e. "it's really neat," right triangle sum of the squares, number series, etc.).
7. Have students determine the relationship of the height of the sighting triangle to its bottom length ( $\frac{3}{4}$ ) – ratio, fractions, division, etc.
8. Have them apply that same relationship to the triangle formed by their position and the rocket's flight.

The rocket's height is  $\frac{3}{4}$  of the distance from the student to the launcher/reference line PLUS the height of the student's eye above the launcher.

Alternately, you can use a 45 degree right triangle for the sight. In that case, the height above eye is the same as the distance to the launcher/reference line. No ratios needed for youngest students.

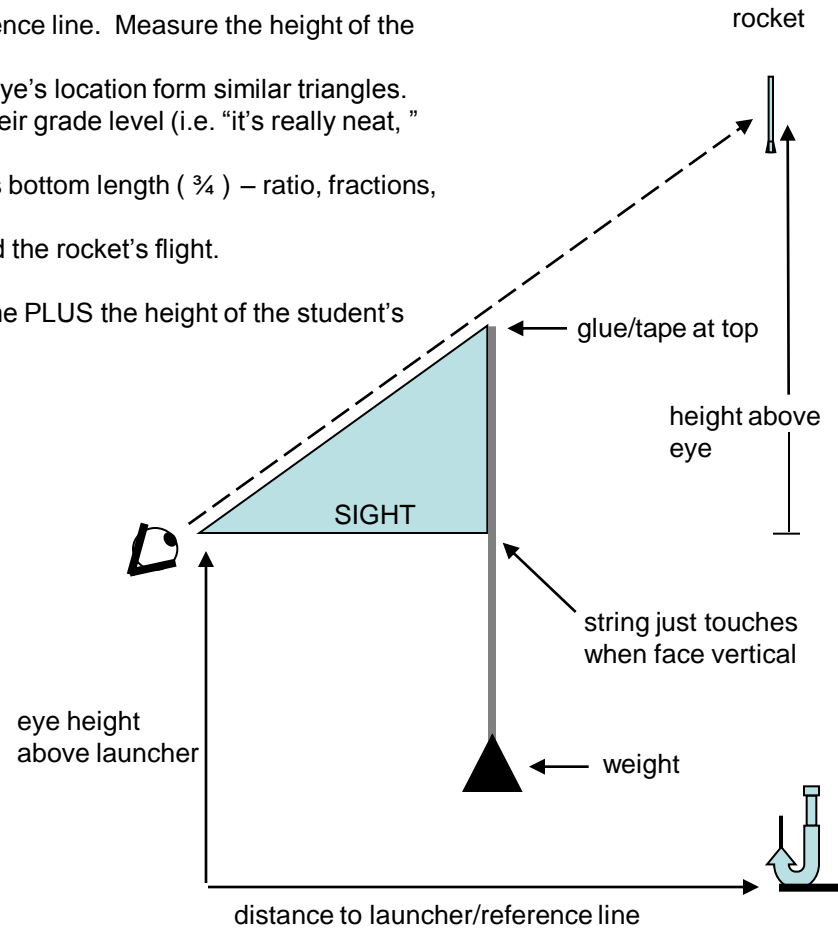
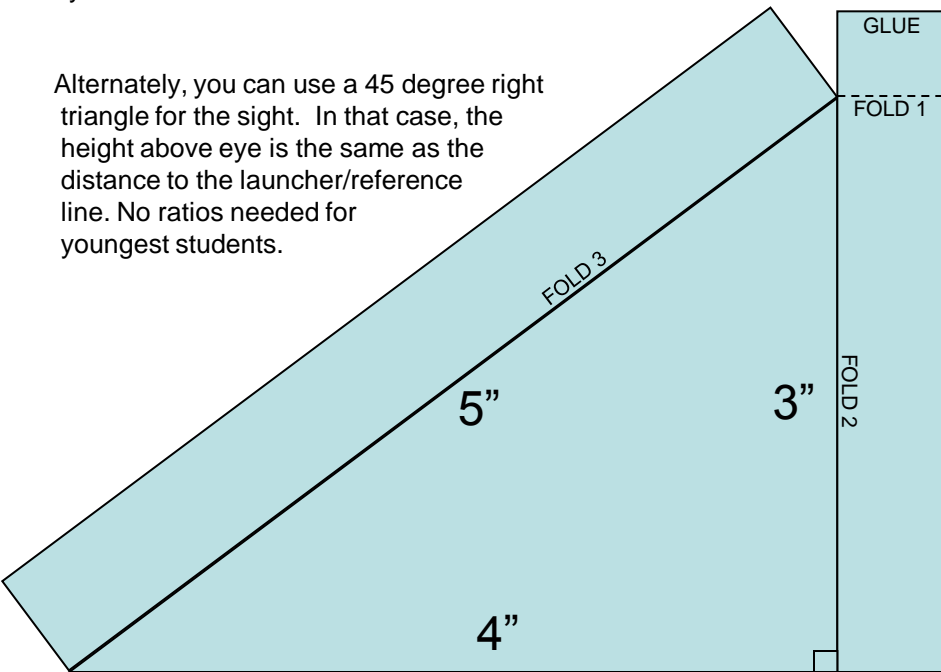

# Measuring height

Trigonometric functions and right triangles:

Upper grades can precisely measure the height of each rocket's flight using a protractor and some string.

1. Attach a string and weight to a protractor as shown.
2. To use, one student holds the protractor steady with the string hanging down the center to ensure it's level – this forms a right triangle (vertical direction is perpendicular to horizontal).
3. Have the measuring team stand a known distance from the launcher (straight up shot) or perpendicular to the reference line where the rocket reaches the highest point of its trajectory.
4. To determine the height of a rocket's flight the student with the straight edge aims at the rocket's high point while the holder notes the angle.
5. Measure the height the protractor is being held.
6. Explain to the students that the tangent of the angle for a right triangle is the ratio of the height the rocket reached above the protractor (opposite side of the right triangle) to the distance from the protractor to the launcher or reference line (adjacent side of the right triangle).
7. Have students determine the tangent of the angle and solve for the height above the protractor, then add the height of the protractor to get the rocket's maximum height.

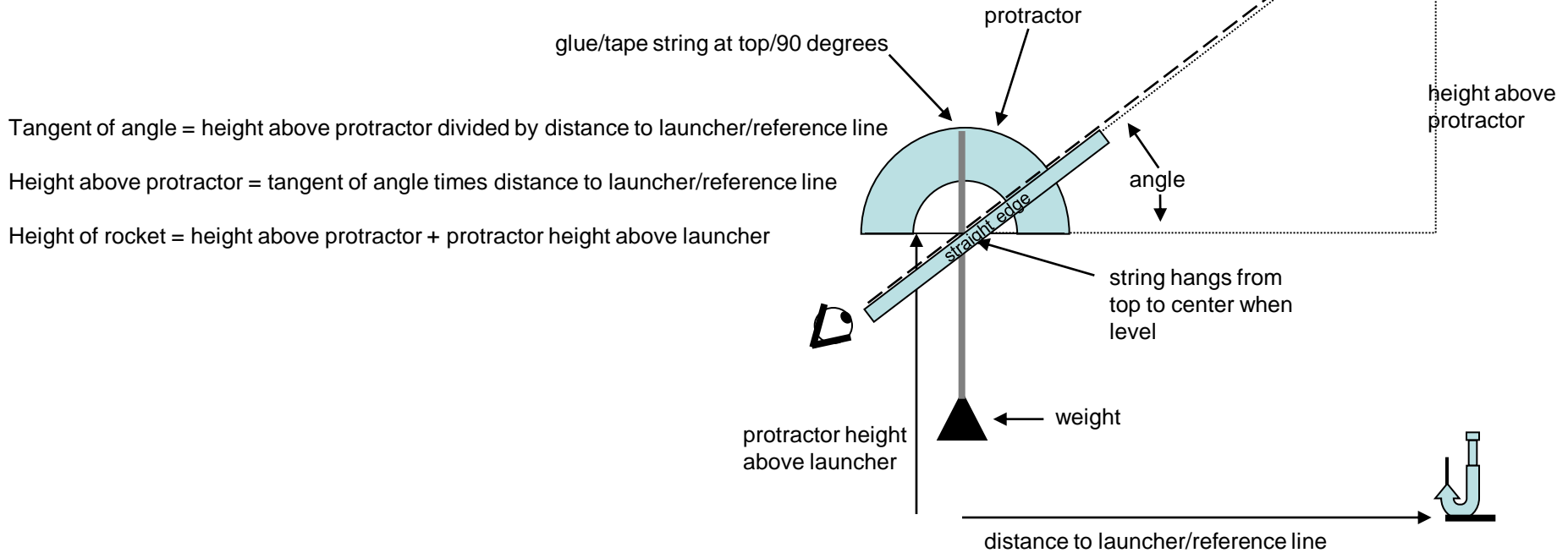

## “Airplane”

You can add simple flat wings to any rocket. Below is a more elaborate winged version for demonstration purposes.

1. Cut out the wing and tail from card stock, then score the dotted lines. Cut out the opening in the middle of the wing.
2. Fold the leading edge completely under and flatten. Fold the remaining scored lines lightly to form a curved wing surface. Fold down the tips of the tail.
3. Plug the front  $\frac{1}{2}$ " of the straw with modelling clay or putty.
4. Tape the tail to the top of the straw at the back end.
5. Tape the wing to the bottom of the straw with the leading edge fold  $1\frac{1}{4}$ " back from the nose ( $8\text{-}1/4$ " straw). The wing should end up with some dihedral as you press the tape tight with the wing tips even and about  $\frac{1}{4}$ " to  $\frac{1}{2}$ " above the surface.
6. Test fly by tossing it gently like a paper airplane and adjust the wing slightly forward if the plane dives violently; aft if it immediately stalls or loops. If it displays no violent tendencies, small adjustments can be made with the trim tabs on the tail to achieve a stable glide (bend tabs up to correct dive, bend tabs down to correct climbing stall/loop).

Launch between 0 and 20 degrees elevation – much higher will cause the glider to stall.

This makes a heavy glider, so it will require close to maximum force to launch.

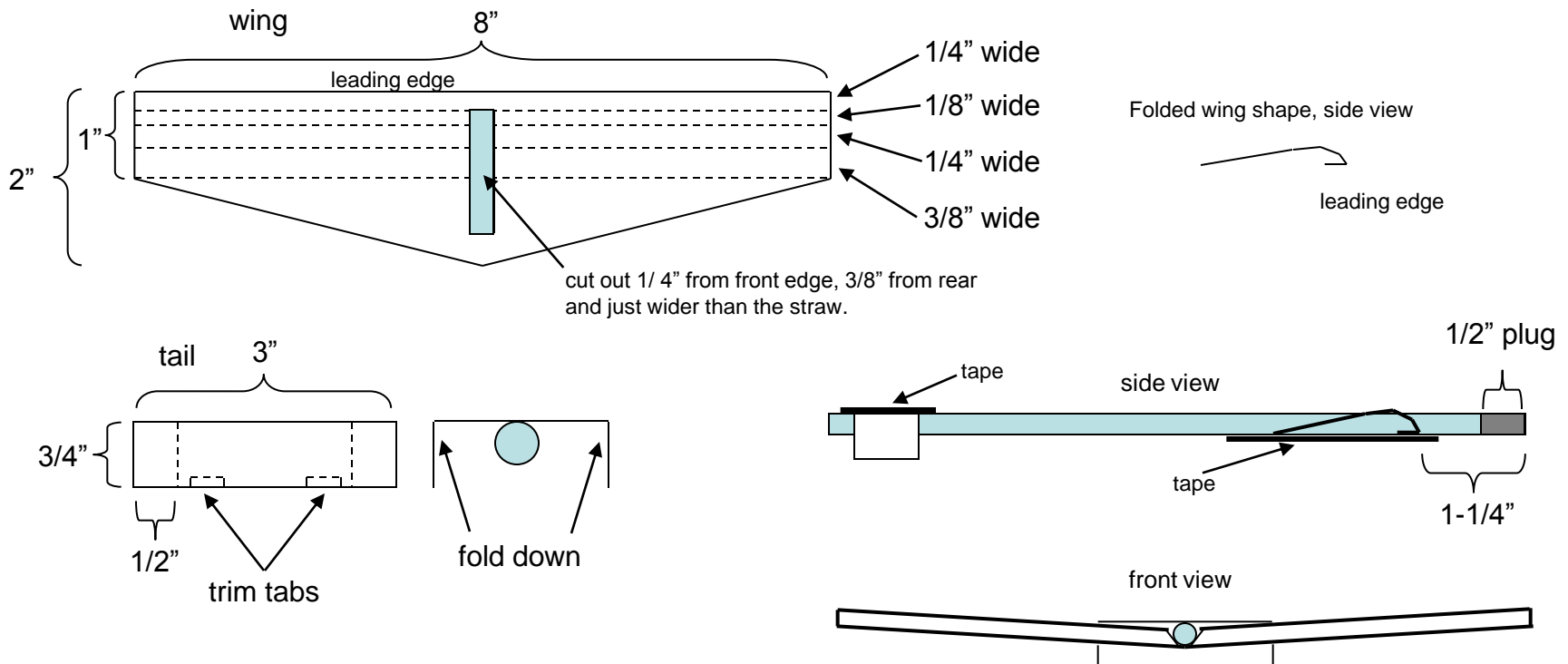

## “Airplane”

You can add simple flat wings to any rocket. Below is a more elaborate winged version for demonstration purposes.

1. Cut out the pattern below from card stock, then score the dotted lines. Cut out the openings in the middle of the wing.
2. Fold the leading edge completely under and flatten. Fold the remaining scored lines lightly to form a curved wing surface. Fold up the tips of the tail.
3. Plug the front  $\frac{1}{2}$ " of the straw with modelling clay or putty.
4. Slide the straw through the openings in the wing as shown, going over the tail section, under the center of the wing, and over the leading edge. This will form and hold the wing curvature. Use small pieces of tape just behind the wing and ahead of the tail to hold the straw in place with the leading edge fold  $1"$  to  $1\frac{1}{4}"$  back from the nose (straw about  $8"$  long).
5. Test fly by tossing it gently like a paper airplane and adjust the wing slightly forward if the plane dives violently; aft if it immediately stalls or loops. If it displays no violent tendencies, small adjustments can be made with the trim tabs on the tail to achieve a stable glide (bend tabs up to correct dive, bend tabs down to correct climbing stall/loop).

Launch between 0 and 20 degrees elevation – much higher will cause the glider to stall.

This makes a heavy glider and a low launch angle increases friction with the launch tube, so it will require a lot of force to launch (plunger raised 5-6").

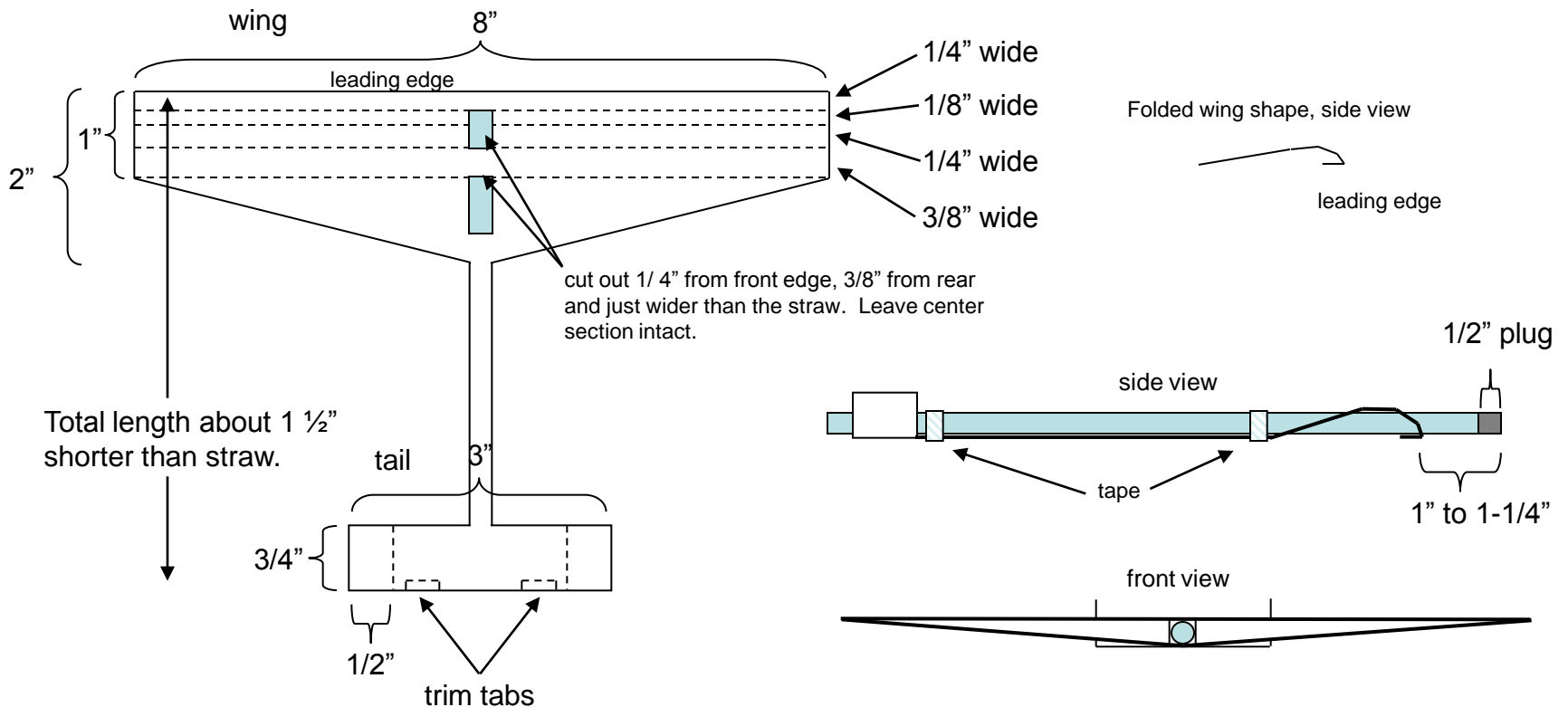





## Galileo Inclined Plane Experiment

### Student Instructions

Drop a few balls and see how they speed up as they fall further and further. Now let some balls roll down the ramp and note how their speed changes as they get further down the ramp. Why do you think Galileo used the ramp to measure the rate instead of dropping objects? Why do you think rolling balls down a inclined plane tells us something about how objects **fall**?

Measuring the Rate of Acceleration, Method 1: In this method you will measure the distance traveled by the ball by marking the position of the ball at equal intervals as measured by a pendulum. Can you think of any other way of measuring equal intervals. Galileo used his heartbeat and a water clock, as well as a pendulum?

Setup:

1. Prop the inclined plane up by just a few books or pieces of wood. You want the ball to roll slow enough to measure, but fast enough so that it starts and rolls freely.
2. Position 4 or 5 people along the ramp with markers and have one person watch a pendulum. The person at the pendulum will call out start at the beginning of a swing and then call out 1, 2, 3 etc. as each subsequent complete swing of the pendulum is completed. The ball will be started when the timer says start and then each time a number is called out a student will mark the position the ball was in when they heard the number.
3. You can then use the string to measure the distance between the marks. Use the first distance as the unit with the string and see how many units long each of the other distances is. If you want, calculate how many multiples of this unit each of the other distances are. Then figure out the total distance traveled at each point (add up all the distances up to each marker):

Time	1 (start to marker 1)	2 (marker 1 to 2)	3	4	5	Trial 1 Distance 1 (use this as unit)	Trial 2 Distance 1 (use this as unit)	Multiples of unit 1	Total distance
------	-----------------------	-------------------	---	---	---	---------------------------------------	---------------------------------------	---------------------	----------------

Measuring the Rate of Acceleration, Method 2: In this method people will call out as the ball passes them and you will try to arrange the people so they call out in a regular pattern with equal periods of time between them. Galileo knew from his music studies that human can recognize deviations from a pattern up to 1/64th of a second.

In this method 5 or 6 people will start by position themselves at equal intervals along the ramp holding their finger as a marker near the ramp to mark the equal intervals. The ball will be released and each person will call out as the ball passes their finger. What is the pattern of the calls when you are spaced equally?

Now try spacing yourselves to make the pattern of your calling out more regular. You may have to experiment a little or you may be able to figure it out by thinking about it. Once you arrange yourselves so that the calling out is perfectly regular, making equal intervals, have each person mark where their finger is and measure as in the previous trial.

Time	1 (start to marker 1)	2 (marker 1 to 2)	3	4	5	Trial 1 Distance 1 (use this as unit)	Trial 2 Distance 1 (use this as unit)	Multiples of unit 1	Total distance
------	-----------------------	-------------------	---	---	---	---------------------------------------	---------------------------------------	---------------------	----------------

Do your two methods give the same results? If not, can you figure out which might be more accurate.

Galileo found that the distance varied with the square of the time? Did you get this result? If not, does this prove Galileo wrong? Why do you think your result might differ from his? How could you prove him wrong in an experiment of this type? How could you prove him right?

Different Weight balls. Galileo did not use this experiment to prove that heavy objects fall at the same rate as light objects See if you can figure out why.

Roll two balls of different weights down the ramp at the same time? Which is faster? Try some different combinations? Do your results prove that heavy objects fall faster? Air resistance isn't as much a factor on the ramp. What other explanations can you think of for the results? Under what conditions can you imagine heavy and light balls rolling down at the same rate?

Cut two 8' sticks of cove molding (less than \$5 each) in half and glue three 48" lengths together as shown below to build the track (or rout two grooves in a long board, or buy fluted or beaded molding). Carefully sand the tracks smooth, wax as needed. Mark out a 1m track.

Mark 30" from the bottom end of the track and attach a riser to raise that point 6" to set an 11.5deg angle. Resulting acceleration should be 1/5g. Steeper track will reduce friction effects but faster motion is harder to follow.

Finger release or use small stick to release balls for timing runs (takes practice!). For runs with two balls of unequal weights, the stopper at the bottom should provide a simultaneous "click." Make multiple runs on alternating tracks to eliminate differences in resistance between the track surfaces.

Ramp angle 20 degrees

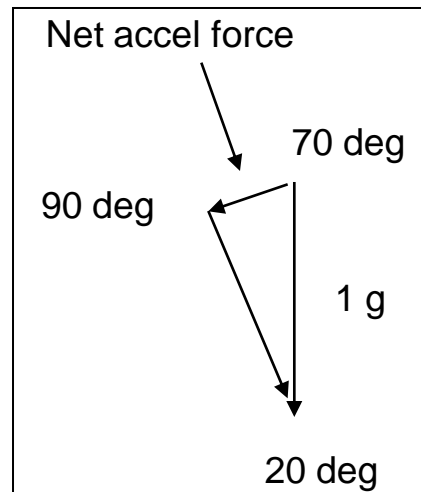
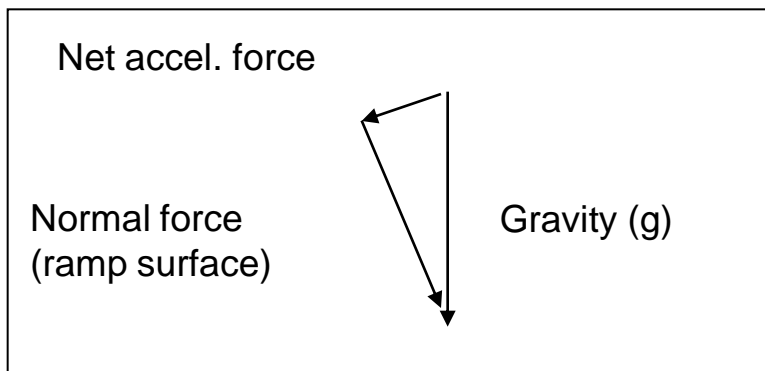

$\sin 20\text{deg} = \text{NetAccel} / 1 \text{ g}$   
 $.34 * \text{g} = \text{Net accel force}$   
 About 1/3 force, slows events by factor of 3. Achieve angle by raising 48" track 16".

$\sin 14.5\text{deg} = .25$  (1/4 g accel)  
 Raise track 12",  
 $\sin 11.5\text{deg} = .20$  (1/5 g)  
 Raise track 9.6".

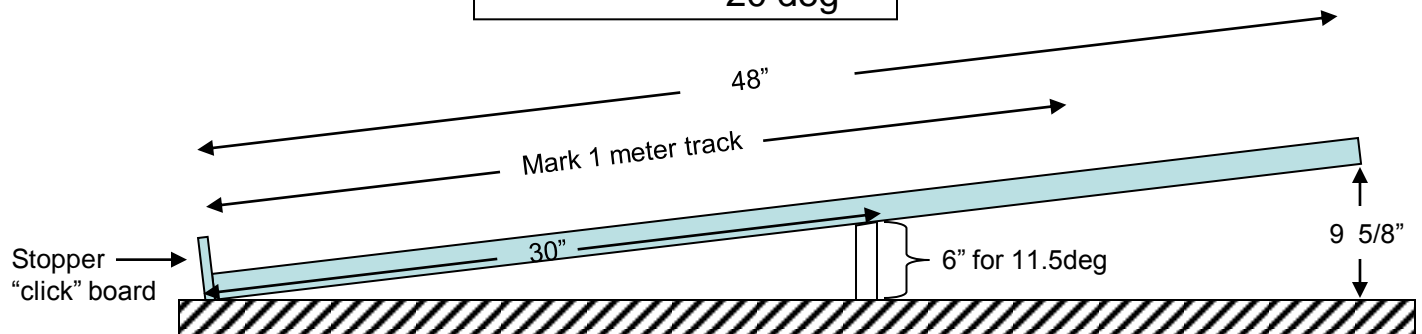
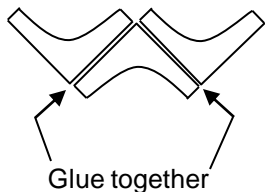

Use of integral rise/run slopes keeps the calculation of g, and setting the riser, simple. Remember to measure along the track (not the table!) for the run and use an easy fraction for the riser. 1 in 5 above needs a 9.6" riser at 48" for max stability.

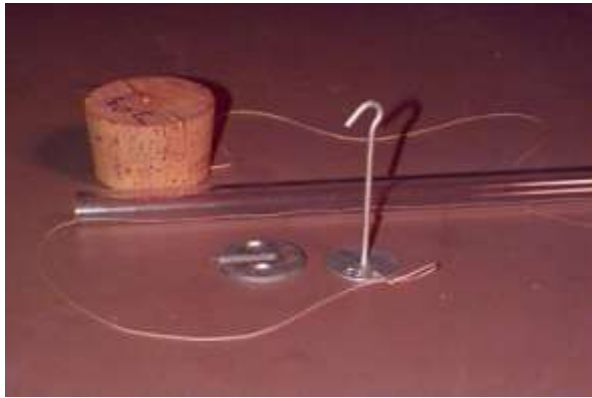

### WHIRLIGIG 1Q40.25

**PURPOSE:** To show that a centripetal force acts as a central force.

**DESCRIPTION:** A cork on a string passes through a narrow tube. A weight hangs from the end. As the cork is whirled overhead the weight is lifted or lowered in proportion to the change in the speed of rotation. Conservation of angular momentum can be demonstrated by letting the circular motion slow down gradually.

The weight will make the radius shorter. The ball's tangential velocity increases, trying to conserve angular momentum. The weight can also be changed to show the difference in angular velocities needed to keep each one suspended.

**EQUIPMENT:** Whirligig made of tube and string, cork and mass hanger.

**SETUP NOTES:** Practice.

*Updated by Jun Qi in 3/13/2000*

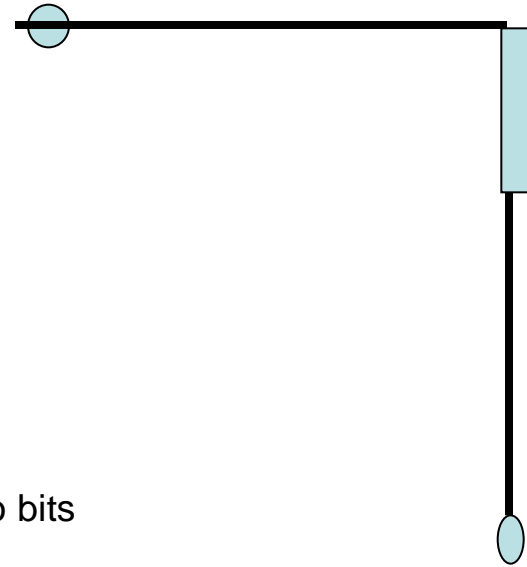

### Simpler whirligig – two bits

Drill a wooden ball (or any lightweight object) and pass string through the hole, knot end of string to retain. Slip string through 6" piece of tubing (scrap pvc, etc.) and attach ½ to 1 oz of fishing sinkers to the bottom. String should be no longer than your height. Sand smooth all edges on the top of the tube so as not to cut the string.

**Rotational motion:** Swinging ball holds up weights, demonstrating centripetal force. Pull down on string to shorten radius and note the ball speeds up as angular momentum is conserved.

**Simple orbital mechanics:** Swing ball in small "orbit" (takes practice), sinker's weight simulates gravity (OK, constant and not inverse square but close enough). Swing harder to increase the size of the "orbit," note the weight rises (showing energy added) and ball slows down (orbital speed decreases). Pull down on string for "retro rocket burn" and note how slowing down to drop to a lower orbit actually speeds up the spacecraft. Ok, more accurate example is to let ball slow down, weight will pull it into a tighter (faster) orbit. Friction on the string may make this difficult (practice), hence the suggestion to pull down on the weight.

## Simultaneous ball drop (courtesy Case Western Reserve University)

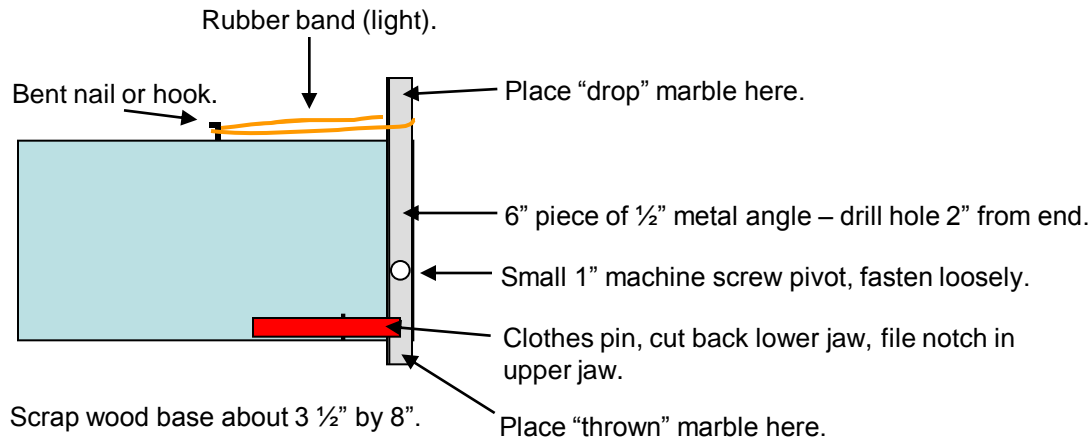

- Take a 6" piece of light metal angle and drill a hole 2" from one end. Fasten this to the wooden base with a small 1" machine screw and nut, making sure the angle can pivot freely.
- Cut off one jaw from a clothes pin and file the remaining jaw into a square edged hook. Attach the clothes pin to the base with a screw through the tail of the bottom leg.
- Insert a small cup hook or bent nail to hold a rubber band as shown.
- Loop a light rubber band around the angle as shown. Too much tension will launch the "thrown" ball across the room – you only need 5 to 10 feet of throw. You can adjust tension by selecting different rubber bands or moving the hook that holds the band.

Fasten clothes pin with screw through lower leg.

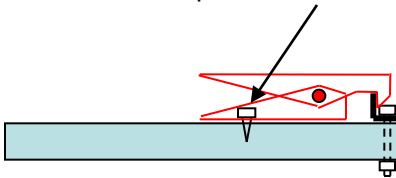

### Parts/Materials

3 1/2 by 8 inch wood base  
 6" of 1/2" light metal angle  
 1" machine screw/nut/washers  
 3/4" screw  
 Small nail or cup hook  
 Clothes pin  
 Rubber band  
 2 small marbles

### DEMONSTRATION: Which falls faster, a thrown ball or a dropped ball?

Set the apparatus flat and level on the edge of a table or desk. Latch the throwing arm (metal angle piece) with the clothes pin and loop the rubber band around it as shown for tension. Set two balls on the throwing arm in the places indicated.

When the clothes pin latch is released, the "drop" ball will fall vertically as soon as the throwing arm pulls out from under it (demonstrating the inertia of the drop ball). The other end of the arm will propel the "thrown" ball forward.

You should hear a simultaneous "click" as both balls hit the floor at the same time (need a room with a hard floor). The horizontal (vector) motion of the thrown ball is independent of its vertical motion accelerated by gravity. Both balls see the same acceleration force from gravity and drop with the same velocity from the same height – hitting the floor at the same time.